

PA50D



Panoramic LCD



Stretch Your Imagination

Featuring a distinctive, “stretched” aspect ratio, these displays fit in spaces which traditional 16:9 displays will not.

Menu boards, ad space and lobby signage all benefit from the eye-catching design.



Highlights

PA50D

Includes wall mount and trim (Top, Left, Right, Bottom).



Unique stretched aspect ratio.



Sleek, unbranded, black powder-coated metal housing.



“Secure-Ready” = No NFC, RF, WiFi, or embedded computing.



Available with both fixed and flexible EDID.



Ability to toggle the display area using a hotkey on remote.

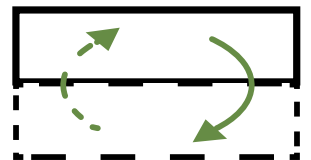

DisplayPort output for duplicating images.

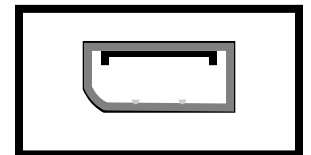

Specifications

Panel Attributes

Panel Technology	50" Stretched LED-LCD
Surface Treatment	Hard Coating (3H), anti-glare treatment
Screen Size (diag.)	49.46"
Native Resolution	1920 x 540
Active Area (mm)	1209.6 x 339.6
Brightness (typ.)	700nit
Contrast Ratio (typ.)	4000:1
Displayable Colors	1.07B (Dithered 10bit)
Viewing Angle	178°/ 178°
Aspect Ratio	32:9

Dimensions, Power & Other

Display Dimensions (W x H x D) + Weight	48.78 x 14.61 x 2.42 (in) - 40lbs
Packed Dimensions (W x H x D) + Weight	55 x 23 x 11 (in) - 48lbs
Display Orientation	Landscape or Portrait
Mounting Pattern (mm)	200 x 200
Electrical Ratings/ Power Type	AC 100 -240V (50/60Hz)/ Power Adapter 24V 3.33A 4pin
Power Consumption (typ.)	55W
Standby Power Consumption	<1W
Heat Output (BTU/hr)	188
Operating Temperature	32°F -104°F
Operating Humidity Range	20~80%
Industrial Reliability	50,000 + hours
Usage Ratings (hrs/days)	24/7**
Warranty	Three year advance replacement (Cover 3/ Quick 3)

****Consult with GPO Display regarding best practices for preventing image retention and for prolonging display lifetime.**

Connectivity

HDMI	2
VGA	1
RS-232	1
DC Input	1
DisplayPort Output	1

Accessories:

- HDMI cable x1
- RS-232 cable x1
- Remote controller x1
- AAA batteries x2
- Power adapter x1
- Power cord x1
- Power adapter “brick” mounting bracket x1

Options:

- Custom housing
- Custom colors
- Custom logos
- Other designs
- Tempered protective glass

Drawings

Front View

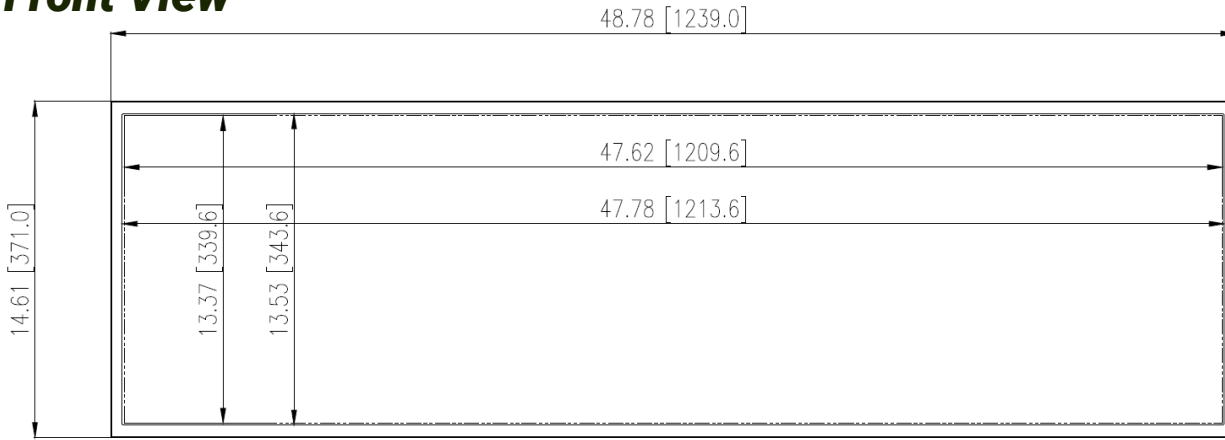

Power Adapter & Mounting Bracket

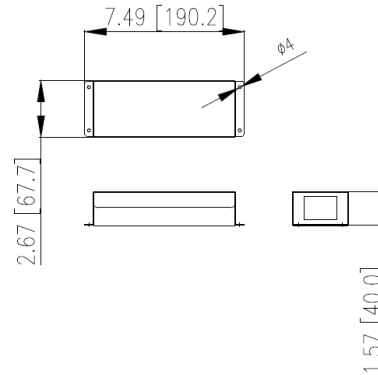

Rear, Side, and Top Views

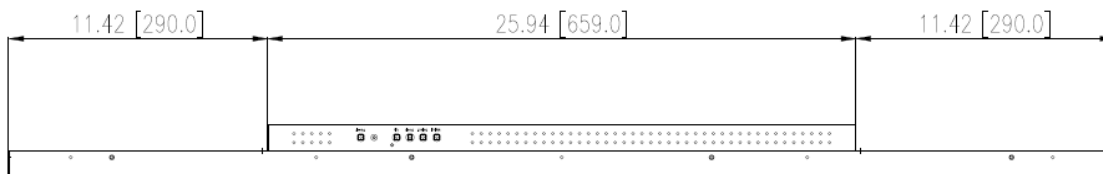
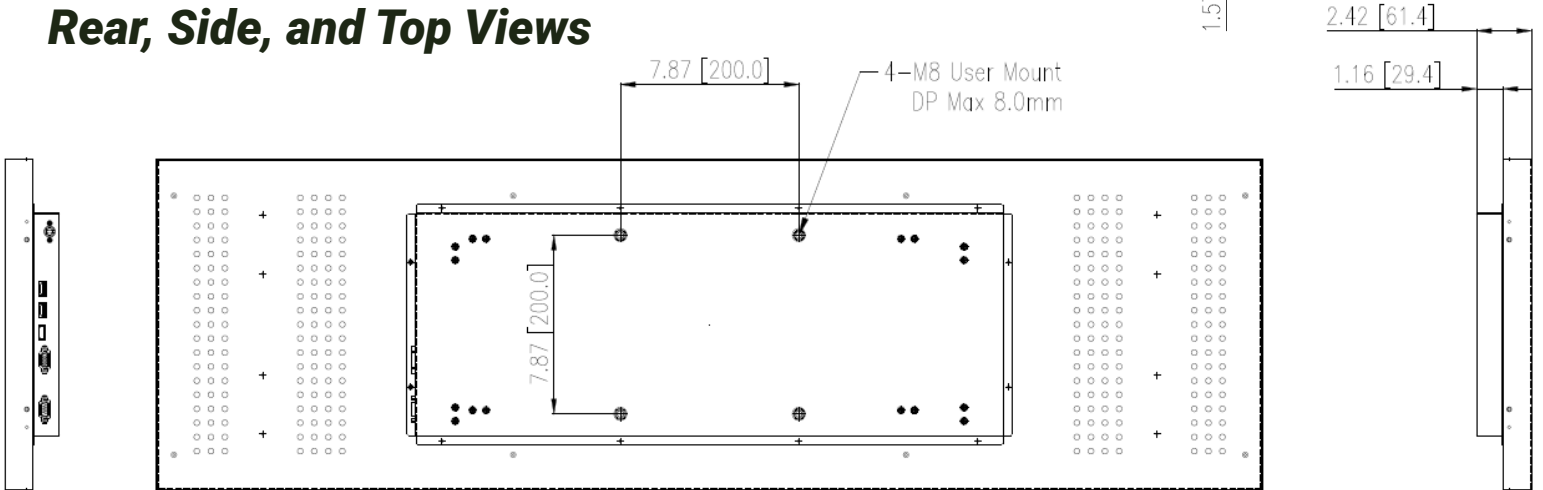

Product specification and design are subject to change without notice.

Copyright 2024, GPO Display All rights reserved. This document may not be copied in any form without written permission from GPO Display

